

Bianco Rainsaver MK3 Installation and Operating Instructions

Bianco Rainsaver MK3 Installation and Operating Instructions

1. Introduction:

The **Bianco Rainsaver MK3** is an Automatic Rainwater / Mains Water Changeover Device designed to provide automatic mains back up for Pressure Pump supply systems.

The **Bianco Rainsaver MK3** is designed to be installed in conjunction with a Pressure Pump supply system that is fitted with a **FLOAT SWITCH** as well as an independent **PRESSURE AND FLOW CONTROLLER** with **LOSS OF PRIME PROTECTION** and **AUTOMATIC RE-START**.

WARNING! The **Bianco Rainsaver MK3** is **NOT A PUMP CONTROLLER!**

2. General Specifications:

Maximum water temperature (mains + pump): 40^o C.

Maximum recommended continuous pump flow: 100 litres per minute.

Maximum recommended pump pressure: 800 kPa.

Maximum recommended mains inlet pressure: 800 kPa.

3. Operation:

The **Bianco Rainsaver MK3** supplies clean rainwater from a rainwater tank and associated pressure pump system, to toilets, laundry, garden taps and household.

Mains water is also connected to the **Bianco Rainsaver MK3** as an automatic back up.

When the pressure pump ceases to supply water because the float switch has detected that the rain water level in the tank is too low, or if there is a power or pump failure, The **Bianco Rainsaver MK3** will automatically change over to supply mains water to meet the household needs.

When the rainwater supply is replenished and the float switches the pump back on, or the power is restored to the pump, the pump will pressurise the **Bianco Rainsaver MK3** and the unit will switch back automatically to supplying tank water to the household.

4. Installation:

4.1 Pump Float Switch installation.

Submersible pumps supplied with the Rainsaver MK3 will have a pump mounted float switch and no adjustments should be necessary, however, the submersible pump should be positioned so that the float switch cannot touch the sides of the rainwater tank, or be less than 200 mm away horizontally from the rainwater tank inlet or outlet. The submersible pump power lead should be taped to the discharge pipe to prevent the float switch becoming tangled with the power lead.

Surface mounted pumps supplied with the Rainsaver MK3 will also have a pump mounted float switch which needs to be installed in the rain water tank.

The float switch for the surface mounted pumps is supplied with an inline connector to assist should the cable be required to run through conduit. Check that the conduit size is appropriate for the inline connector.

Important: Switch off power supply and ensure all parts are clean and dry before unmating and mating the inline connector.

To **unmate** the connector, pull the collar back in the direction of the arrow.

To **mate** the connector, line up the alignment ribs, then push the two halves together. Full engagement is indicated by a click.

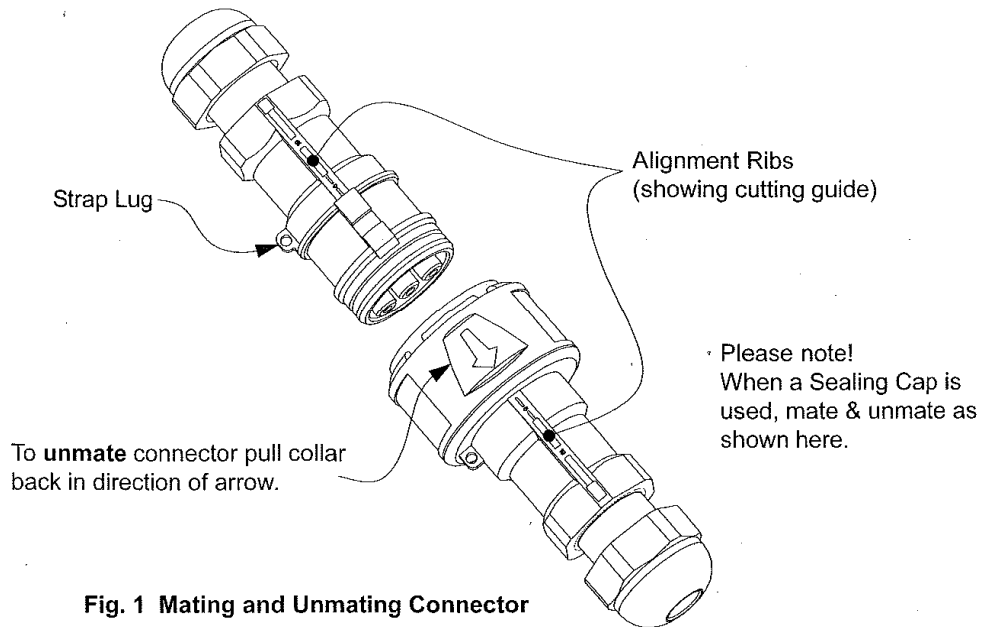

The float switch supplied prevents the pump from running dry and allows automatic switch over to mains supply. It is supplied complete with a counterweight and water tank mounting plate, and is designed to enter the rainwater tank from the roof of the rainwater tank.

Choose a location on the roof of the rainwater tank to cut the 85mm hole required. The centre of the hole should be at least 200 mm away from the side of the tank as well as being 200mm away horizontally from tank rainwater entry and rain water tank outlet. Any shavings should be removed with a vacuum cleaner.

Uncoil and lay out the float switch cable. Move the counterweight so that it is **200 mm from the float switch.**

Position the water tank mounting plate so that the distance between the mounting plate and the end of the float switch is **at least 50 mm less than the depth of the tank when measured from the float switch access hole**, and tighten the cable gland and conclamp.

4.2 Rainsaver MK3 installation.

The **Bianco Rainsaver MK3** can be **Wall mounted** or **Pump Mounted** i.e. mounted directly onto a pressure pump outlet. The steel wall mounting bracket, which is connected to your **Bianco Rainsaver MK3**, can be rotated to allow the unit to be wall mounted in either direction, or may be removed for pump mounting.

4.2.1 Wall Mounting:

The **Rainsaver MK3** can be remotely mounted any distance from the pump.

The **Rainsaver MK3** can be mounted outdoors on a flat vertical surface.

The **Rainsaver MK3** can be mounted with the mains inlet pointing in either direction.

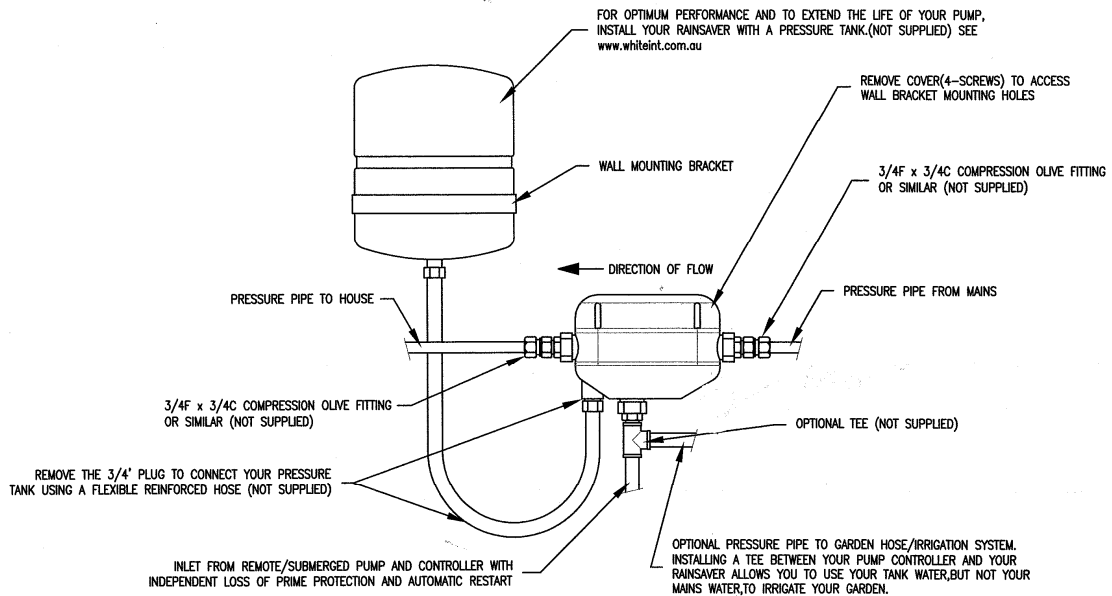

Wall Mounting Instructions:

- To reverse the mounting direction, so that "Mains" inlet will be on the left side and "House" outlet on the right, follow the first steps of Pump Mounting Instructions below to remove and reverse the mounting bracket. Then continue:-
- Remove the **Bianco Rainsaver MK3** lid by unscrewing the 4 Phillips head screws
- Hold the **Bianco Rainsaver MK3** in the desired position and mark the screw centres through the keyhole slots in the mounting bracket. Return the **Bianco Rainsaver MK3** to the box.
- Drill and insert mounting hardware into the mounting surface (wall). Insert screws leaving a few millimetres under the head to allow insertion of the mounting bracket
- Mount the **Bianco Rainsaver MK3** onto the screws through the keyhole slots in the mounting bracket. Tighten screws to secure the bracket to the wall
- Replace the **Bianco Rainsaver MK3** lid and re-tighten the four (4) lid screws.

4.22 Pump Mounting:

Rainsaver MK3 can be mounted directly onto the outlet of the pump with the adaptor supplied with the Rainsaver-ready pump. If another size threaded port is found on the pump or controller outlet use quality standard plastic threaded pipe fittings to adapt.

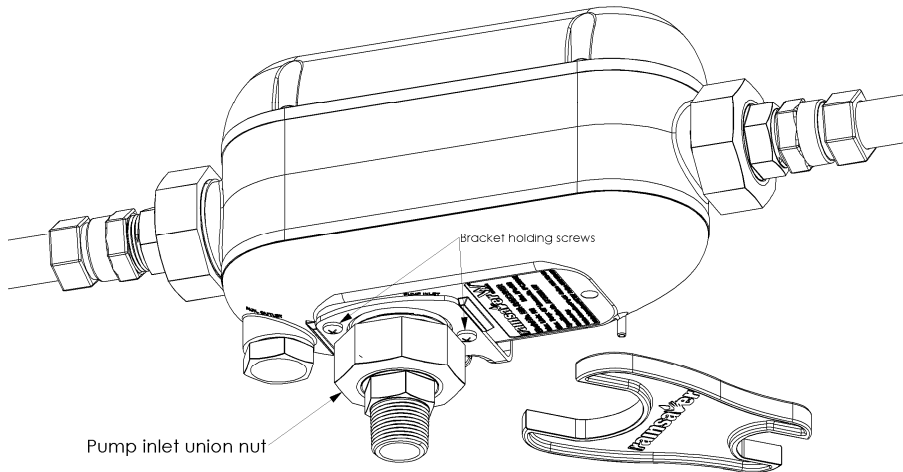

Pump Mounting Instructions:

- Remove wall mounting bracket by unscrewing the lower (Pump Inlet) union nut using the plastic spanner provided. Remove the union nut and pipe being careful not to lose any of the internal components.
- Unscrew the two bracket holding screws and remove the bracket.
- REPLACE THE BRACKET HOLDING SCREWS into the housing. This will stop insects creating a nest inside the Rainsaver Unit.
- Replace the lower union nut and pipe being sure that internal components are in place and that the o-ring is properly seated.
- Leave the lower union nut slightly loose to allow fitting and alignment to pump.
- Attach the 3/4" BSPT male pipe fitting to the pump outlet, either directly, or using plastic threaded pipe fittings as required, and tighten using the spanner provided.
- Once the 3/4" BSPT pipe fitting is secured to the pump and the **Rainsaver MK3** aligned as required, tighten the lower nut with the plastic spanner provided.

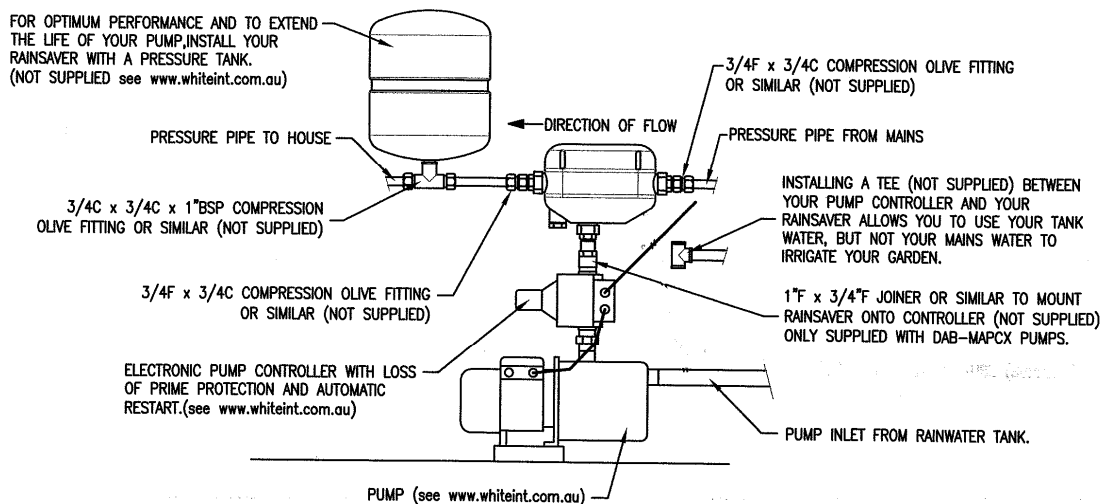

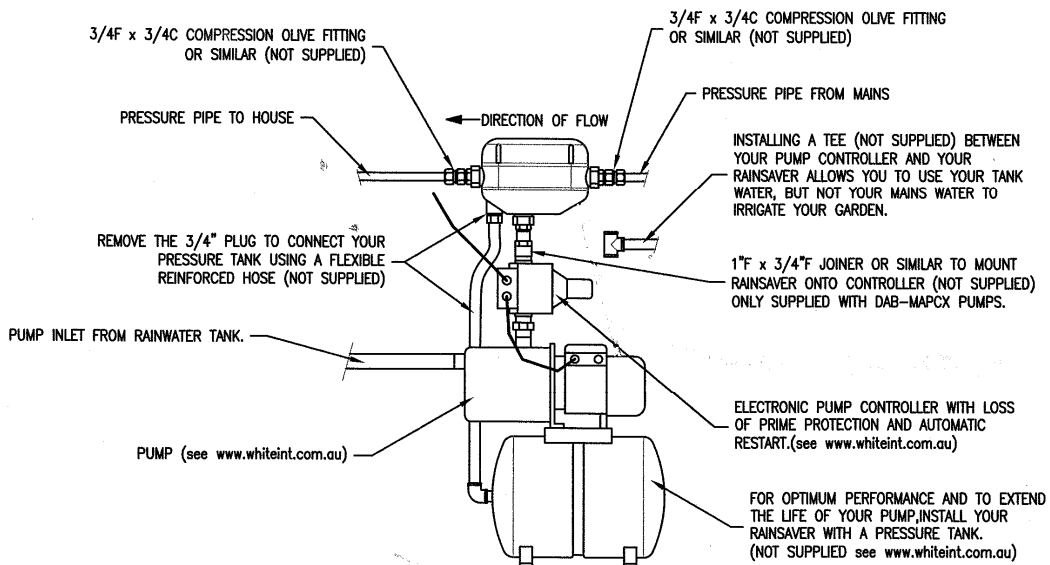
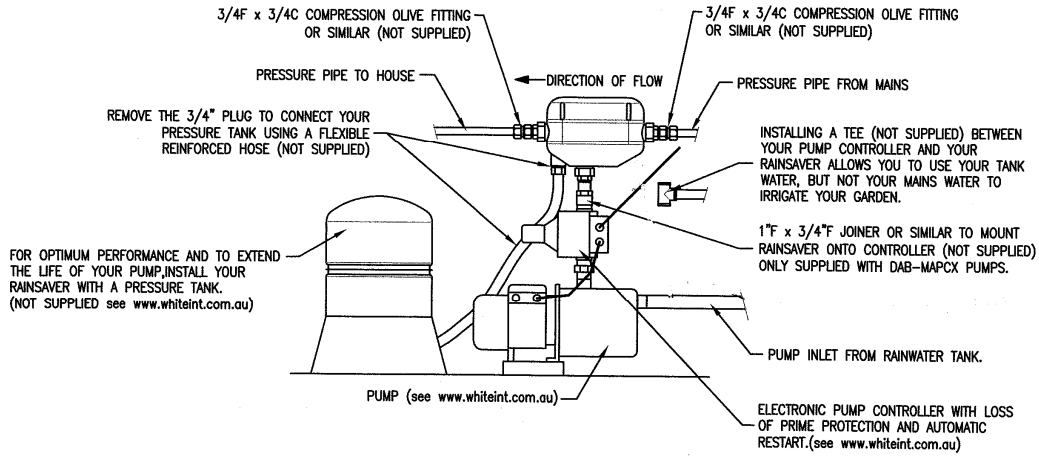
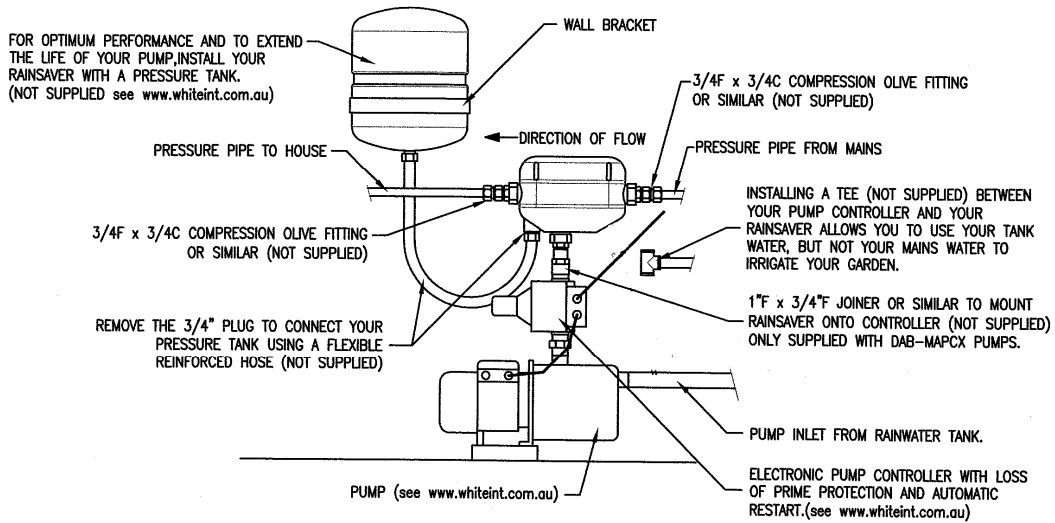

4.4 Filtration and Water Quality

The **Bianco Rainsaver MK3** is designed to operate on **clean** rainwater and clean Mains water supply, and as such, the rainwater tank should be fitted with an inlet strainer and a suitable first flush device.

The **Bianco Rainsaver MK3** is fitted with internal strainers to ensure continuous reliable service. These internal strainers may restrict the water flow of the unit, especially if they become clogged, and they should be cleaned periodically.

White International strongly recommends the use of a strainer or filter upstream from both the rainwater and mains inlet connections of the **Bianco Rainsaver MK3**. If quality filters are installed upstream from the Rainsaver MK3 inlets, then the supplied internal strainers can be removed, at the discretion of the installing plumber.

To access the internal strainers, both prior to installation and afterwards for maintenance, undo the inlet union nuts with the spanner supplied. Pull connection pipe work sideways to reveal the strainer, situated inside the union pipe, and remove for cleaning.

Additional water filters may be required at tap outlets to assist in the filtration of tannins etc that may discolour the water. Also check the water tank and first flush device manufacturers' instructions regarding periodic servicing that is required.

4.5 Plumbing

Plumbing connections should be carried out by a licensed plumber.

Use of flexible pipe connections and isolation vales is recommended to assist in alignment and servicing and to reduce any transmitted noise.

Use a standard $\frac{3}{4}$ " compression x F.I. union or Compression x F.I. elbow fitting to connect between $\frac{3}{4}$ " copper tubing and $\frac{3}{4}$ " BSPT threaded pipe fitting at the "MAINS" inlet, "PUMP INLET" (if unit is wall mounted), and "HOUSE" outlets.

Use standard $\frac{3}{4}$ " BSP female threaded fittings to connect to $\frac{3}{4}$ " BSPT threaded pipe fitting when connecting other types of piping.

DO NOT REMOVE THE UNION NUT AND $\frac{3}{4}$ " BSPT PIPE FITTING AND ATTEMPT TO CONNECT PIPE WORK DIRECTLY TO THE BODY OF THE UNIT!

DO NOT ATTEMPT TO CONNECT COPPER OR PLASTIC PIPE, USING COPPER OR NYLON OLIVES, AND COMPRESSION NUT DIRECTLY TO THE $\frac{3}{4}$ " BSPT PIPE FITTING!

Always use the spanner provided, or correct open ended spanner, when tightening fittings.

All pipe-work and outlet fittings from the Bianco Rainsaver MK3 must be labelled to AS3500.

The **Bianco Rainsaver MK3** control incorporates a dual check valve to prevent cross connection between mains and rainwater. Connection to an underground rain water tank, or local water supply authorities, may require additional, or higher safety level, back flow prevention, and your licensed plumber can advise you on this.

The incorporation of an additional "Tee" fitting between the tank water pressure pump supply, and the **Bianco Rainsaver MK3** lower "PUMP INLET", will allow the householder to use collected rainwater, but NOT mains water supply, to irrigate gardens and lawns, or wash cars.

4.6 Pressure Tank Outlet

The **Bianco Rainsaver MK3** is supplied with an additional outlet specifically designed for the installation of a pressure tank.

White International strongly recommends the installation of a pressure tank to improve the performance of your water supply system such as **GWS Energy Savers**.

The installation of a pressure tank will:

- Reduce wear and tear on your pump by significantly reducing the number of starts
- Reduce your electricity consumption by significantly reducing the number of starts
- Reduce the incidence of “pressure drop” when opening a tap
- Stop your pump kicking in every time you open a tap or because of a small leak, like a dripping tap, or toilet cistern.

To install a WATERMARK approved pressure tank:

- Turn off both mains water supply pressure and your rainwater tank pump and supply
- Open a tap to remove all pressure from the system
- Using the spanner supplied, remove the $\frac{3}{4}$ ” plug from the “AUX. OUTLET” port. Note that there is an o-ring inside the body of the Rainsaver which can be left in place if using a $\frac{3}{4}$ ” BSP fitting, or removed if using a $\frac{3}{4}$ ” BSPT fitting.
- Use a suitable flexible reinforced hose with $\frac{3}{4}$ ” BSP or BSPT MALE THREAD to connect a WATERMARK approved pressure tank such as a **GWS Energy Saver** to your **Bianco Rainsaver MK3**.
- **Carefully follow the manufacturer’s instructions regarding pressurization of your pressure tank.**

4.7 Pressure Tank Pre-charge.

To ensure optimum performance and system life, the Pressure Tank pre-charge needs to be set by filling the pressure tank with air through the air valve so that the air pressure is the same pressure as the mains water pressure.

Pre-charge the pressure tank before it is installed by using an air pump or using the local service station facilities.

Cautions:

In conjunction with this manual, read and understand the installation and maintenance manual for the water pump that is to be connected to the **Bianco Rainsaver MK3**.

The **Bianco Rainsaver MK3** and any pump connected to it are not to be used by children or infirm persons and must not be used as a toy.

A licensed plumber should carry out plumbing connections.

Servicing of the **Bianco Rainsaver MK3** and, or water pump should only be carried out by qualified persons.

Do not clean the **Bianco Rainsaver MK3** with abrasive or petroleum based fluids, and do not use hydrocarbon propelled sprays on or around the **Bianco Rainsaver MK3**.

5. Sound Emissions.

The **Bianco Rainsaver MK3** is virtually silent but may emit noises associated with the flow of water through the unit.

In any case, the pump, which is connected to the **Bianco Rainsaver MK3**, may emit sound levels, which may inconvenience you or your neighbours, or may operate during normal sleeping hours, which may be prohibited by local government regulations. If this is the case, your pump can be switched off during the night or may be operated from a time clock. Your **Bianco Rainsaver MK3** will automatically supply your house with Mains water supply while the pump is inactive.

6. Maintenance.

Ensure that water flowing through the **Rainsaver MK3** is as free from dirt and foreign matter as conditions allow.

Periodically inspect the rainwater tank inlet strainer and the first flush device. Periodically inspect strainers if fitted upstream from the **Bianco Rainsaver MK3**.

Periodically inspect and clean the internal strainers at "MAINS" inlet and "PUMP INLET". To access the internal strainers, undo the inlet union nuts with the spanner supplied. Pull connection pipe work sideways to reveal the strainer, situated inside the union pipe, and remove for cleaning.

If you rarely run out of rain water and do not turn your pump off at night, operate the valve within the **Bianco Rainsaver MK3** at least monthly by switching off the power to your pump and flushing a toilet, or opening a tap connected to the system, thus allowing mains water to flow through the unit for a short period of time.

Periodic inspection and cleaning of the units internal components is highly recommended. Your plumber can perform this work, and can advise on the maintenance periods as dictated by individual situations and water quality.

7. Trouble shooting.

Consult the manuals supplied with the water pump and its controller if fitted in addition to the following guide.

1. Mains flow is not available or low when Pump is switched off or not operating.
 - a. Isolation valve, if fitted, is not open.
 - b. Debris has jammed the check valve closed or is caught in the moving parts or bleed hole of the internal valve.
 - c. External Inlet strainer / filter, if fitted, is blocked.
 - d. Internal inlet strainer is blocked.

2. Pump flow is not available or low when pump is operating through Bianco Rainsaver MK3.
 - a. Pump has lost its prime.
 - b. Isolation valve, if fitted, is not open.
 - c. Debris has jammed the internal check valve closed, or has blocked the check valve.
 - d. External Inlet strainer / filter, if fitted, is blocked.
 - e. Internal inlet strainer is blocked.

Installation Dimensions

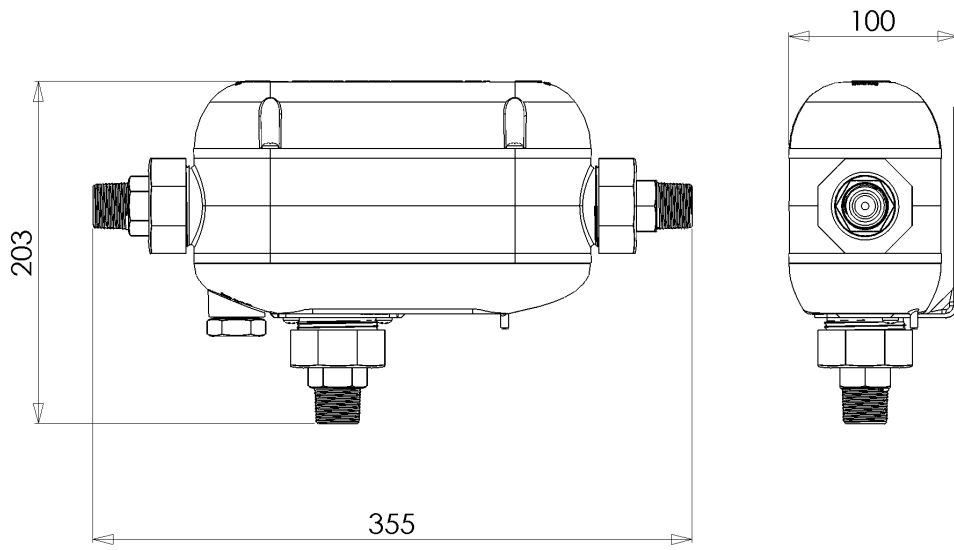

Typical Installations.

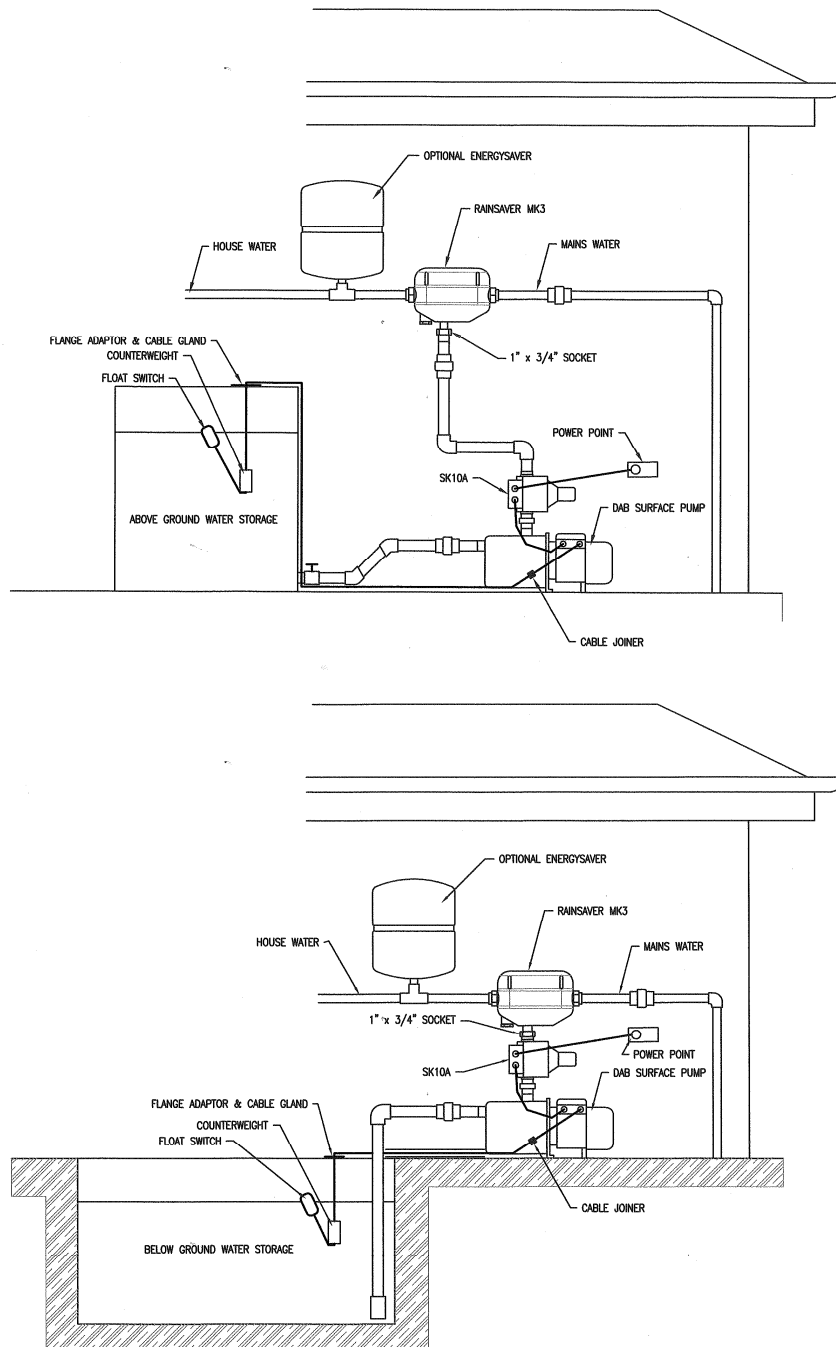

DAB or BIANCO Surface Mounted Pumps

Typical Installations.

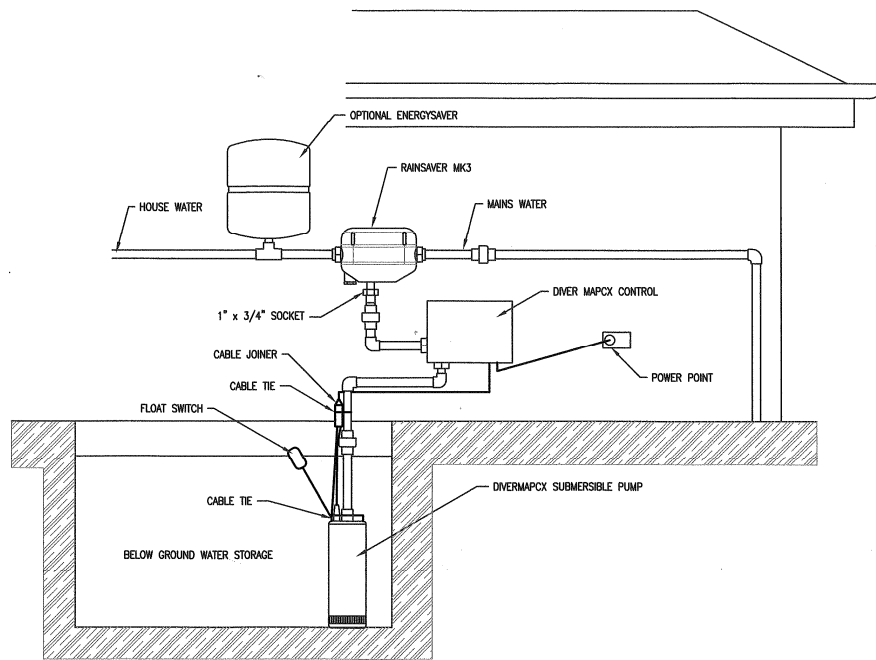
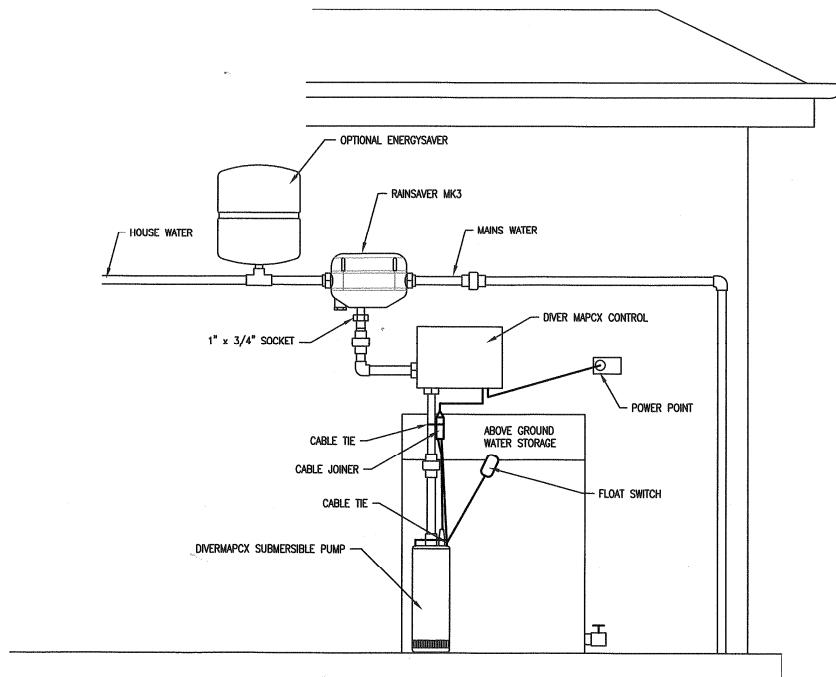

TESLA DIVERxxMAPCX Submersible Pump

Typical Installations.

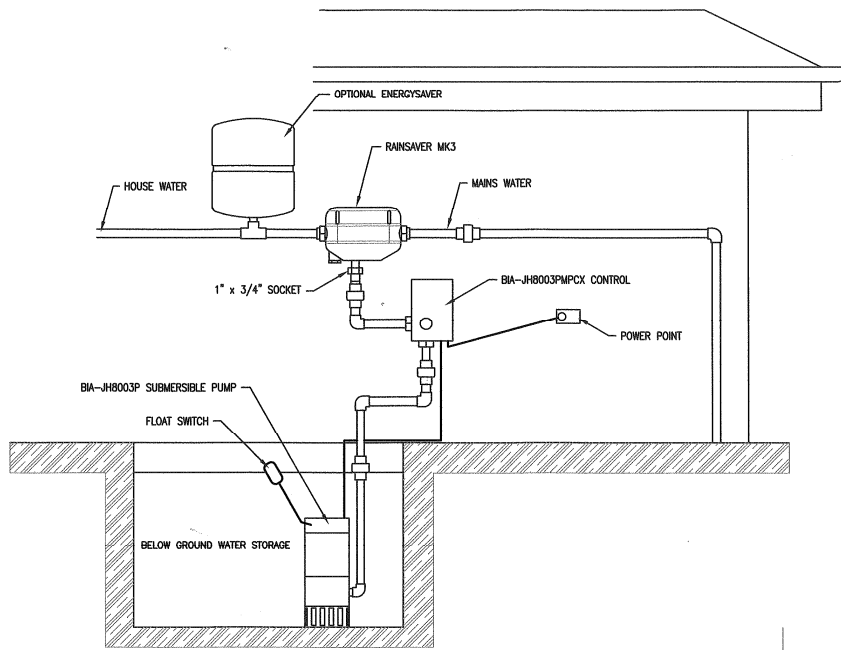
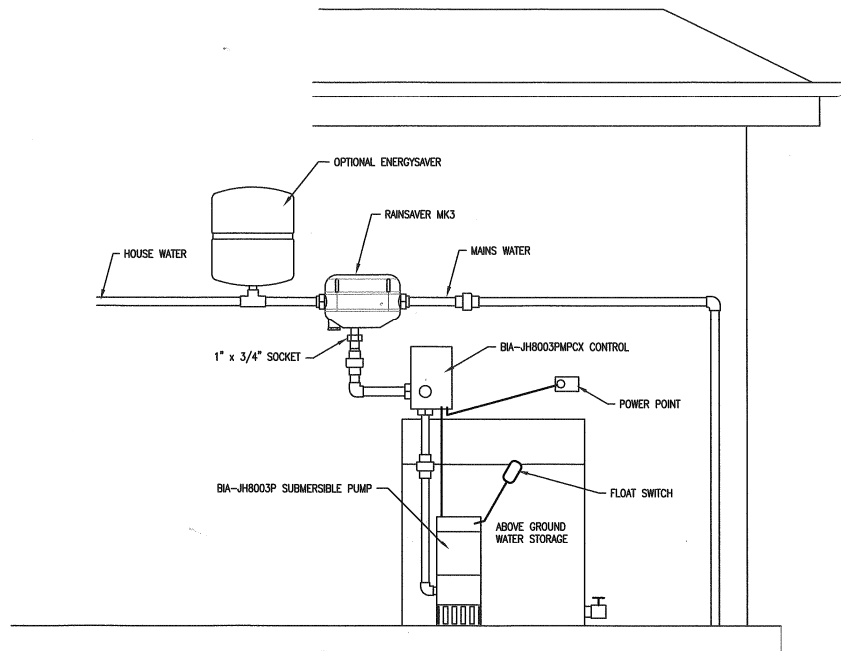

BIANCO JH8003PMPKCX Submersible Pump

2 YEAR WARRANTY* **RAINSAVER MKII&MKIII**

Terms & Conditions

Subject to the provisions of the Trade Practices Act and Goods and Consumer Protection Legislation of various States)

- 1) White International Pty Ltd / White International NZ Ltd warrants that the **Bianco RAINSAVER MKII and MKIII** that we distribute, are free from defects in workmanship and materials, for 2 years from the date of purchase. Subject to our conditions of warranty White International will repair any defective products free of charge on site within 25 kilometres of our nearest authorized in-field Bianco RAINSAVER Service Agent. In the event that service is required outside the 25 km radius of the nearest in-field Bianco RAINSAVER Service Agent, arrangements for the payment of additional travel cost must be made between the "owner" and the "service agent" before work is carried out.
- 2) The warranty includes in field labour costs where the **Bianco RAINSAVER MKII or MKIII** including pump is installed within a 25 km radius of an authorised in-field Bianco RAINSAVER Service Agent. This warranty excludes transportation costs to and from White International or its appointed service agents, defects due to non-compliance with installation instructions, neglect or misuse, inadequate protection against the elements, low voltage or use or operation for purposes other than those for which they were designed or where equipment is not readily accessible. For further information regarding the suitability of your intended application contact us on our Sales Hotline.
- 3) The 2 Year Warranty refers to **Bianco RAINSAVER MKII and MKIII** after the 1st AUGUST 2009, and is not transferable to another Bianco Rainsaver product and only applies to the original owner, purchaser or end user, and is subject to the Trade Practices Act and Goods and Consumer Protection legislation of various states.
- 4) Our warranty commences from the date of purchase of the above mentioned product. Proof of purchase is required before consideration under warranty is given. Record your date of purchase in the space below and retain this copy for your records.